

SAMEDIA®

FASTER • STRONGER • SAFER



CATALOG



When the job demands **only the best**,
you need **SAMEDIA Professional Diamond Tools**.

www.samedia.com



FASTER • STRONGER • SAFER

SAMEDIA Diamond Tools, the choice of professionals worldwide, are now available across the United States of America and Canada.

Asked for by name wherever the job demands only the best, and featuring SAMEDIA's patented **SHOXX Blades** technology, our premium diamond tools are faster, stronger and safer, which means the job gets done quick and right at every time.

Manufactured in Germany since 1961, our game-changing blades are delivered to you from our Chicago warehouse, meaning professionals in every part of the country can count on SAMEDIA to get the job done.

Try our blade today, and be amazed by the difference the right choice of blade can make for you and your customers.

Cédric Sauret

Business & Marketing
Development Manager
Phone: +33 6 31 43 03 85
Email: cedric.sauret@samedia.com

Enrico Mariotti

Managing Director
Phone: +32 (478) 42 32 35
Email: erico.mariotti@samedia.com

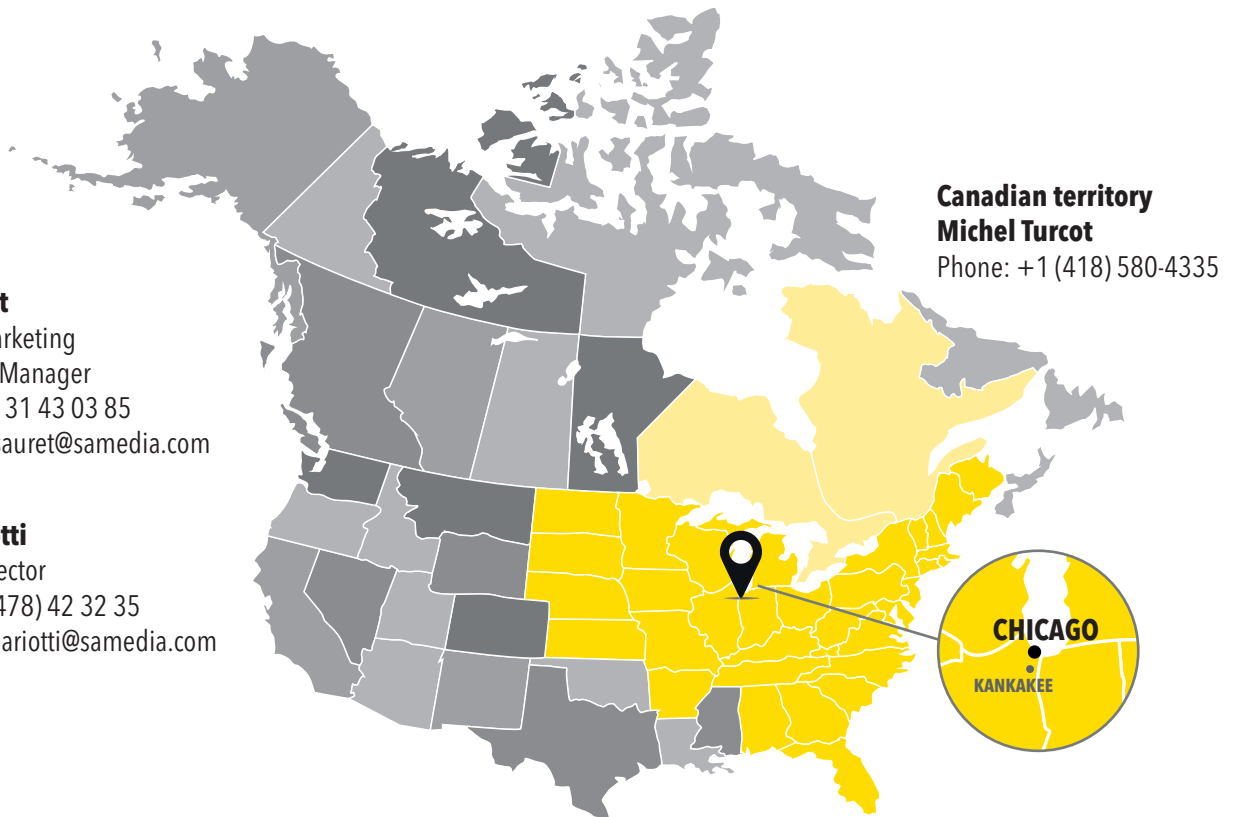

Canadian territory
Michel Turcot
Phone: +1 (418) 580-4335

 **SAMEDIA Corp Headquarters**
233 South Wacker Drive
Suite 4400, 44th Floor
Chicago, IL 60606 - USA
Email: sales@samedia.com

SAMEDIA Operations Center
601 N. 5th Avenue.
Kankakee, IL 60901 - USA
Phone: **(779) 701-5211**
Email: sales@samedia.com

CONCRETE

Page 13-18

MATERIALS

- Reinforced concrete
- Concrete products
- Washed concrete

TOOL TYPES

- Diamond blades
- Core drill (page 42)

UNIVERSAL MASONRY

Page 19-22

MATERIALS

- Concrete
- Brickwork
- Highly dense sandstone bricks
- Bricks

TOOL TYPES

- Diamond blades

GRANITE

Page 23-26

MATERIALS

- Natural stone
- Hard stone
- Hard stoneware

TOOL TYPES

- Diamond blades
- Diamond cut & grind blades

TILES

Page 27-30

MATERIALS

- Porcelain stoneware
- Ceramic
- Glazed stove tiles
- Granite tiles
- Marble

TOOL TYPES

- Diamond blades
- Diamond hand grinding pads

ASPHALT

Page 31-32

MATERIALS

- Asphalt
- Screed

TOOL TYPES

- Diamond blades

MULTI-PURPOSE

Page 33-34

MATERIALS

- Concrete
- Asphalte

TOOL TYPES

- Multi-purpose Diamond blades

SPECIAL

Page 35-41

MATERIALS

- Clinker
- Iron
- Green concrete
- Metal / stainless steel
- Concrete
- Screed
- Tile adhesive
- Coatings

TOOL TYPES

- Diamond blades
- Diamond crack chaser
- Corundum blade
- Abrasive flap wheels
- Vacuum brazed diamond blades
- Carbide coated cutting blades
- Cup wheels

SAMEDIA DIAMOND TOOLS, THE CHOICE OF PROFESSIONALS WORLDWIDE

For over 55 years, we have been at the cutting edge of diamond tool innovation and engineering, operating from our state-of-the-art facilities in Denzlingen, Germany.

We ship to more than 60 countries around the world, wherever professionals demand only the best.

- Large and flexible production capacity.
- Quality control system, ISO 9001-certified.
- Significant cost benefit for our customers.
- Higher efficiency rate on site.
- Always available to ensure our tools are delivered on time to your job site.

Call SAMEDIA to experience the difference and appreciate the key advantages for your job site needs.



SAMEDIA factory - Germany



FASTER • STRONGER • SAFER

INTRODUCING *SHOXX*, OUR WORLDWIDE PATENTED TECHNOLOGY

At SAMEDIA, we know that innovation only makes sense when a real difference is experienced on site by the professionals. With *SHOXX*, you get not one, but three major improvements to your work on site:



• **FASTER** •

SHOXX reduces your labor cost by 50%.



• **STRONGER** •

SHOXX guarantees you both **SPEED** and **LONGER LIFETIME VALUE!**



• **SAFER** •

SHOXX guarantees you up to 3 times more resistance to breakage. No blade is safer in the world!



VIDEO SHOWS THE SAFETY

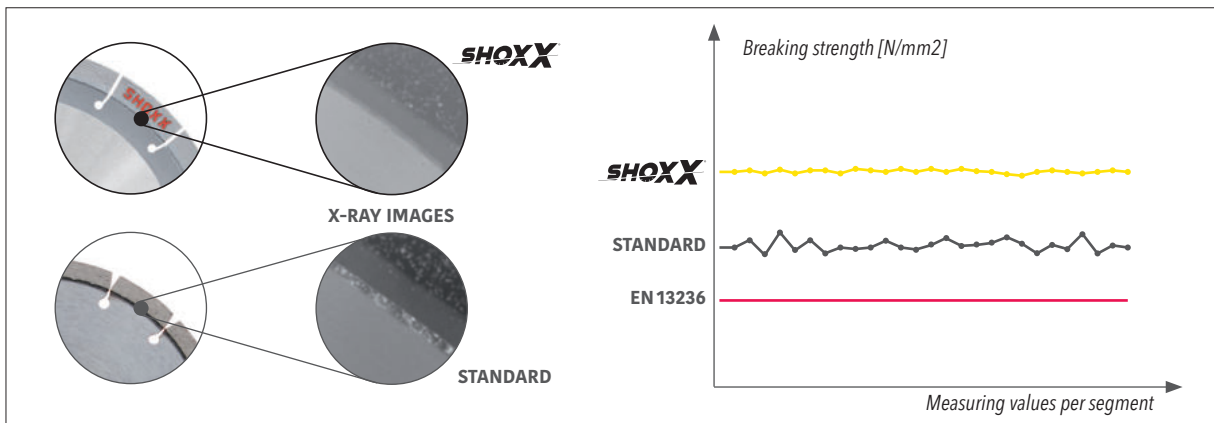

Deep and porefree welding of the *SHOXX* segments

PROFESSIONAL **DIAMOND TOOLS**

Besides these three major improvements on your job sites, **SHOXX** also guarantees **significantly reduced vibrations** when using hand-held gas saw.

This makes the cutting operation smoother and much more comfortable for the operator.

REDUCED VIBRATIONS THANKS TO *SHOXX*

Due to our geometric segment design, our **SHOXX** cutting disks achieve significantly reduced vibration stress. This results in fewer work breaks.

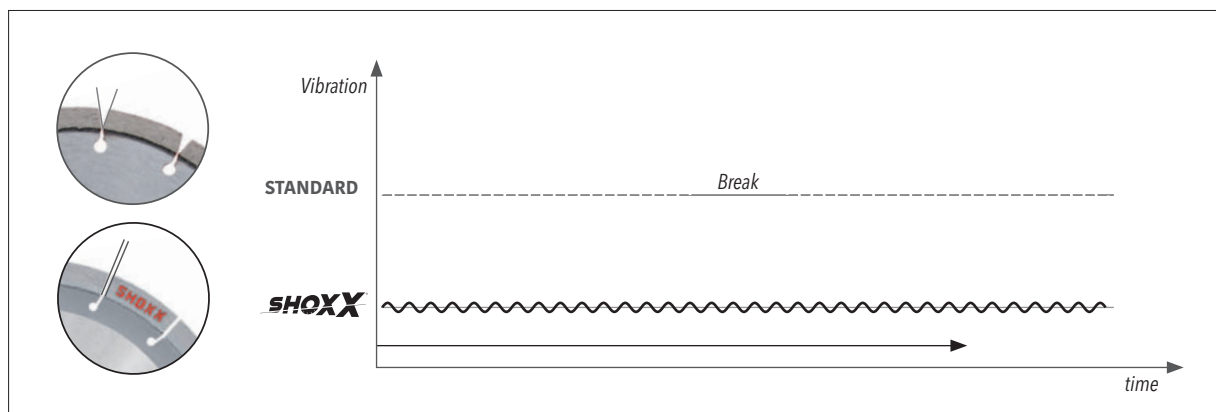

Reduced vibration thanks to the **SHOXX** technology

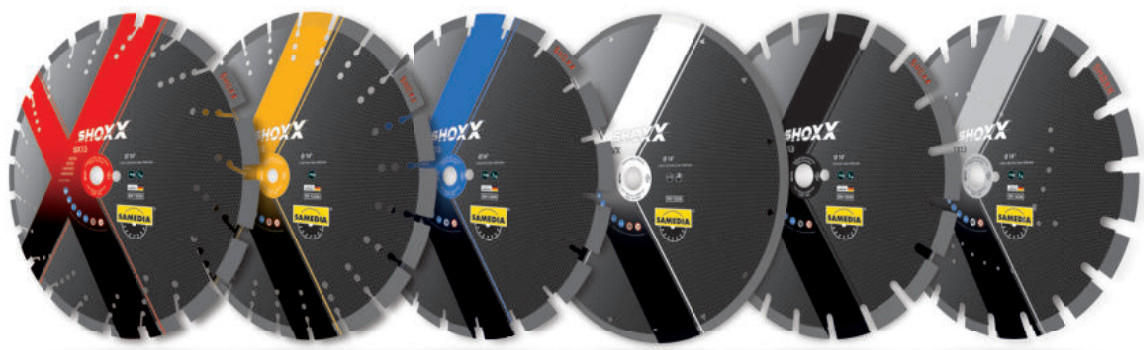

NEW
SHOXX-DESIGN

SHOXX - BENEFITS AT A GLANCE



Speed



Long-life products



Versatility



Safety



Intensive continuous
operation



THE GENUINE TECHNOLOGY
BY SAMEDIA



SYMBOLS



OUR QUALITY LEVELS

Our product range is divided into 3 categories and are easily identifiable with their unique labels.



High-performance tools for intensive use with maximum versatility, cutting speed and life time - **MADE IN GERMANY.**



Premium quality for high requirements.
MADE IN GERMANY
(laser-welded tools only).



Standard tools with optimum price-performance ratio.

COLOR CODE APPLICATION

CONCRETE

UNIVERSAL MASONRY

GRANITE

TILES

ASPHALT

MULTI-PURPOSE SPECIAL

MACHINES SYMBOLS

Angle grinder

Walk behind saw

High speed saw

Tile cutter

Wall saw

Grinder

Table saw

Wall chaser

Bridge saw

Coring machine

Block cutting saw

Drilling machine

Floor grinder

SYMBOLS



WET CUT

With a few exceptions, our tools are suitable for performing dry and wet cuts.



SEGMENT HEIGHT

REDUCTION RING

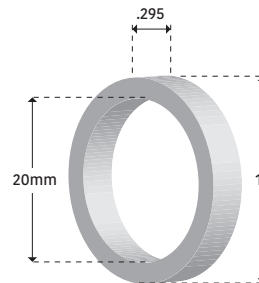

1" PH and Bushing 20mm x.295

PICTOGRAMS

The following pictograms can be found on our tools:



Read the operating instructions



Wear protective gloves



Wear ear protection



Wear a protective mask



Wear safety glasses



Do not use damaged tools



Do not use to roughen

APPLICATION RECOMMENDATION

In our catalog we have divided the recommended use of our tools into two categories:

● **IDEALLY SUITED**

◐ **WELL SUITED**

OUR QUALITY & SAFETY GOALS

SAMEDIA guarantees that all our products are compliant with **EN 13236** standard to ensure safer working conditions.

A SUSTAINABLE DEVELOPMENT APPROACH

SAMEDIA complies with the most rigorous environmental regulations such as **ISO 14001**.

SAMEDIA, MEMBER OF THE FOLLOWING INTERNATIONAL ORGANIZATIONS



STRONG MARKETING SUPPORT

In-store display:





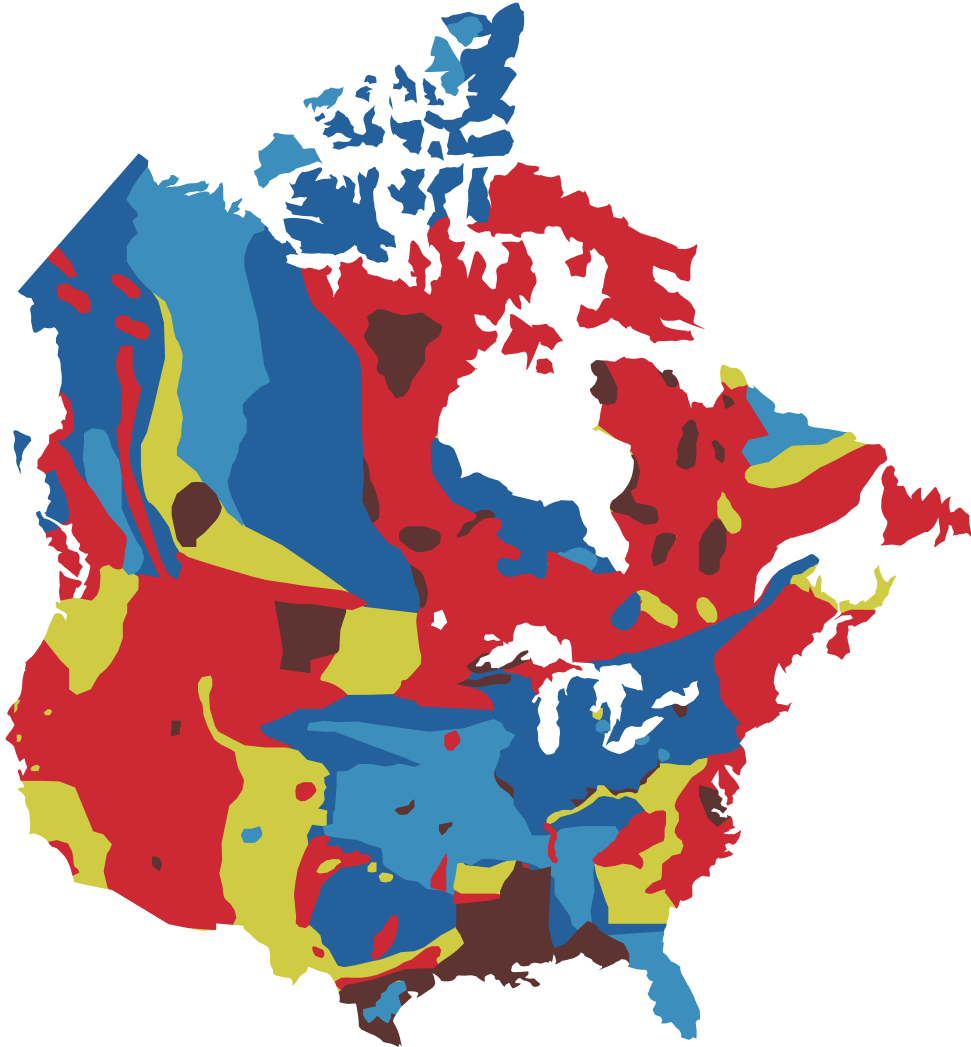

Triangular small display

AGGREGATE MAP FOR USA AND CANADA



AGGREGATE CLASSIFICATION:

-  **SOFT** (Soft Limestone, Sandstone, Dolomite Limestone, Siliceus, Soft Shell)
-  **MEDIUM SOFT** (Pit Gravel, Limestone, Dolomite)
-  **MEDIUM** (Medium Hard River Rock, Medium Traprock, Decomposed Graniot, Medium Crushed Gravel)
-  **MEDIUM HARD** (Granite, Slate, Traprock, Basalt, Quartzite)
-  **HARD** (Hard Chert, Quartz, Flint Rock, Hard River)



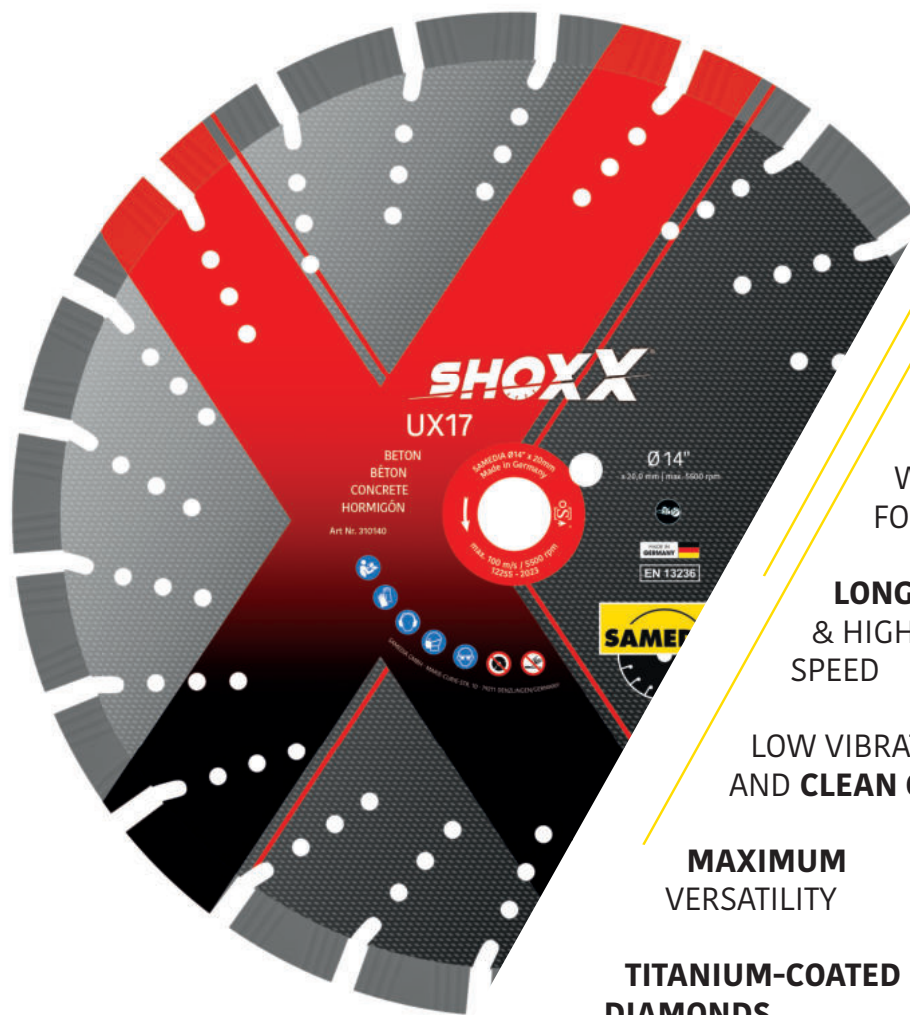

HIGHEST
 SEGMENT HEIGHT
 ON THE MARKET:
11/16"

HIGHEND-
 DIAMOND BLADE

WITH **SHOXX**
 FORGED SEGMENTS

LONGEST LIFE TIME
 & **HIGHEST CUTTING**
 SPEED

LOW VIBRATION
 AND **CLEAN CUT**

MAXIMUM
 VERSATILITY

TITANIUM-COATED
 DIAMONDS

SHOXX UX17

ITEM No.	SIZE - INCHES	NUMBER OF SEGMENTS
510 137	9 x .110 x 7/8	15
510 138	12 x .110 x 20 mm	19
510 139	12 x .110 x 1 PH*	19
510 140	14 x .118 x 20 mm	22
510 141	14 x .118 x 1 PH*	22
510 200	16 x .126 x 20 mm	25
510 201	16 x .126 x 1 PH*	25
511 054	18 x .142 x 1 PH*	25

MATERIALS

- (Strongly) reinforced concrete ●
- Washed concrete ●
- Concrete products ●
- Granite ●
- Natural stone ●
- Lime sandstone ●
- Brickwork ●
- Roof tiles ●
- Ductile cast iron ●



Additional blade sizes available on request.

 * included ring: 1" to 20mm x .295.

SHOXX® RX13



FEATURES

- High-end diamond blade with SHOXX forged segments
- Segment height: 1/2"
- Maximum cutting speed
- Clean cut
- Ideal for angle grinders, high speed saws and wall chasers

MATERIALS

- (Strongly) reinforced concrete ●
- Washed concrete ●
- Concrete products ●
- Granite ●
- Lime sandstone ●
- Brickwork ●
- Ductile cast iron ●
- SML pipes ●

ITEM No.	SIZE - INCHES	NUMBER OF SEGMENTS
510 618	4.5 x .094 x 7/8	8
510 574	5 x .094 x 7/8	9
510 619	6 x .094 x 7/8	11
510 620	7 x .094 x 7/8	13
510 508	9 x .102 x 7/8	15
510 621	12 x .110 x 20 mm	20
510 608	12 x .110 x 7/8	18
510 622	12 x .110 x 1	20
510 528	14 x .118 x 20 mm	21
510 529	14 x .118 x 1	21
510 623	16 x .126 x 20 mm	24
510 624	16 x .126 x 1	24

Additional blade sizes available on request.

SHOXX® BX13



FEATURES

- High-end diamond blade with SHOXX forged segments
- Segment height: 1/2"
- The highest life time & cutting performances
- Low vibration and clean cut

MATERIALS

- (Strongly) reinforced concrete ●
- Washed concrete ●
- Concrete products ●
- Granite ●
- Natural stone ●
- Brickwork ●
- Roof tiles ●
- Sandstone brick ●

ITEM No.	SIZE - INCHES	NUMBER OF SEGMENTS
510 064	4.5 x .094 x 7/8	8
510 058	5 x .094 x 7/8	9
510 522	5.5 x .094 x 7/8	10
510 625	6 x .094 x 7/8	11
510 609	7 x .094 x 7/8	13
510 044	9 x .102 x 7/8	15
510 763	12 x .110 x 20 mm	20
510 065	12 x .110 x 1 PH*	20
510 048	14 x .118 x 20 mm	21
510 049	14 x .118 x 1 PH*	21
510 067	16 x .126 x 20 mm	28
510 057	16 x .126 x 1 PH*	24
510 220	18 x .142 x 1 PH*	25
600010	20 x .142 x 1 PH*	30
600 011	24 x .142 x 1 PH*	34

Additional blade sizes available on request.

* included ring: 1" to 20mm x .295.



SHOXX® WBX

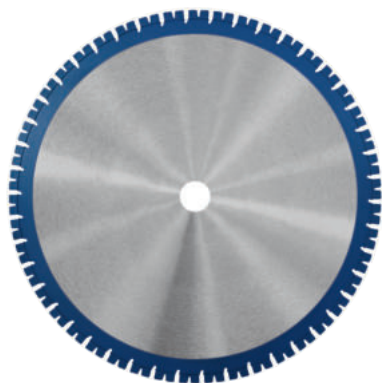

FEATURES

- High-end wall saw blade with SHOXX forged segments
- Segment height: 3/4"
- For wall saws up to 33 HP
- Ideal for high-frequency machines
- Flush holes patterns without charge on request

MATERIALS

Reinforced concrete	●
Concrete products	●
Old concrete	●
Brickwork	◐

ITEM No.	SIZE - INCHES	NUMBER OF SEGMENTS
510 094	24 x .189 x 60	36
510 095	26 x .189 x 60	38
510 096	32 x .189 x 60	46
510 097	36 x .189 x 60	52
510 098	40 x .177 x 60	52
510 099	48 x .177 x 60	62

Other wall saws available: WLX (electric wall saw up to 11 KW), WFX (wall saw up to 35 kW).
Additional blade sizes available on request.

SHOXX® UB13

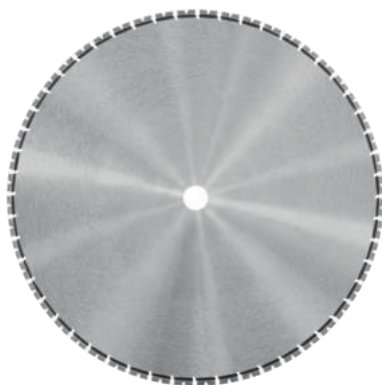

FEATURES

- High-end diamond blade with SHOXX forged segments
- Segment height: 1/2"
- The highest life time & cutting performances
- Ideal for block saws

MATERIALS

Reinforced concrete	●
Concrete products	●
Lime sandstone	●
Bricks/poroton	●
Granite	◐

ITEM No.	SIZE - INCHES	NUMBER OF SEGMENTS
510 578	36 x .181 x 60	52

Additional blade sizes available on request.

MASTER BGM



FEATURES

- Premium diamond blade
- Segment height: 1/2"
- Long-life products & precise cut

MATERIALS

- Reinforced concrete
- Concrete products
- Granite
- Brickwork
- Sand-lime brick

ITEM No.	SIZE - INCHES	NUMBER OF SEGMENTS
510 830	4.5 x .094 x 7/8	8
510 538	5 x .094 x 7/8	9
510 539	9 x .102 x 7/8	15
510 831	12 x .110 x 20 mm	18
510 832	12 x .110 x 1 PH*	18
510 540	14 x .118 x 20 mm	21
510 541	14 x .118 x 1 PH*	21
510 833	16 x .126 x 20 mm	24
510 834	16 x .126 x 1 PH*	24

Additional blade sizes available on request.

* included ring: 1" to 20mm x .295.

MASTER BSE



FEATURES

- Premium diamond blade
- Segment height: 7/16"

MATERIALS

- Concrete products
- Reinforced concrete
- Brickwork

ITEM No.	SIZE - INCHES	NUMBER OF SEGMENTS
510 365	4.5 x .087 x 7/8	8
510 024	5 x .087 x 7/8	9
510 367	7 x .102 x 7/8	14
510 025	9 x .102 x 7/8	15
510 026	12 x .110 x 20 mm	20
511 057	12 x .110 x 1	20
510 090	14 x .118 x 20 mm	24
510 027	14 x .118 x 1	24
511 058	16 x .126 x 20 mm	26
510 120	16 x .126 x 1	26
510 121	18 x .142 x 1	25

Additional blade sizes available on request.

MASTER USM

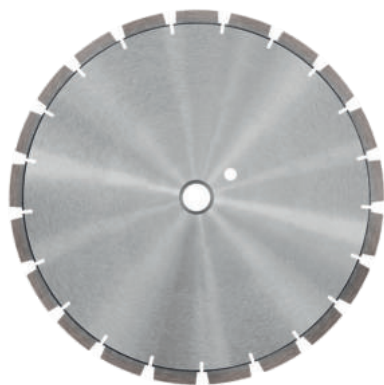

 EN 13236 compliant



MADE IN GERMANY 

LASER WELDED 

FEATURES

- Premium diamond blade
- Segment height: 7/16"
- Long-life products and precise cut
- Ideal for block saws

MATERIALS

Concrete products	●
Granite	●
Natural stone	●
Sand-lime brick	●
Brick	●
Poroton	●
Reinforced concrete	◐

ITEM No.	SIZE - INCHES	NUMBER OF SEGMENTS
511 353	12 x .110 x 1	21
510 950	14 x .118 x 1	21
510 951	16 x .126 x 1	24
510 952	18 x .142 x 1	25
510 953	20 x .142 x 1	30
510 954	24 x .142 x 1	34
600 013	26 x .157 x 1	36
510 955	28 x .157 x 1	40
600 058	30 x .157 x 1	42

Additional blade sizes available on request.

MASTER BFM

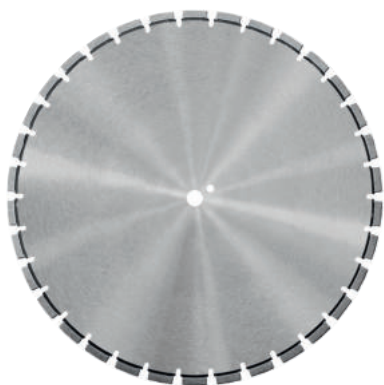

 EN 13236 compliant



MADE IN GERMANY 

LASER WELDED 

FEATURES

- Premium diamond blade
- Segment height: 7/16"
- For floor saws up to 20 HP

MATERIALS

Old concrete	●
Concrete products	●
Brickwork	●
Brick	●
Reinforced concrete	◐
Granite	◐
Lime sandstone	◐

ITEM No.	SIZE - INCHES	NUMBER OF SEGMENTS
510 971	18 x .142 x 1 PH	25
510 972	20 x .142 x 1 PH	30
510 078	24 x .142 x 1 PH	34
510 929	26 x .142 x 1 PH	36
510 079	28 x .142 x 1 PH	40
600 006	30 x .142 x 1 PH	42
510 080	32 x .142 x 1 PH	45

Additional blade sizes available on request.

TECHNIC USM



FEATURES

- Standard laser welded diamond blade
- Segment height: .590
- **Very good value for money**
- Gas saw use only

MATERIALS

- Concrete products
- Reinforced concrete
- Building materials

ITEM No.	SIZE - INCHES	NUMBER OF SEGMENTS
600 026	12 x .110 x 20 mm	21
600 027	14 x .126 x 20 mm	24
600 028	16 x .126 x 20 mm	28

Additional blade sizes available on request.



SHOXX®

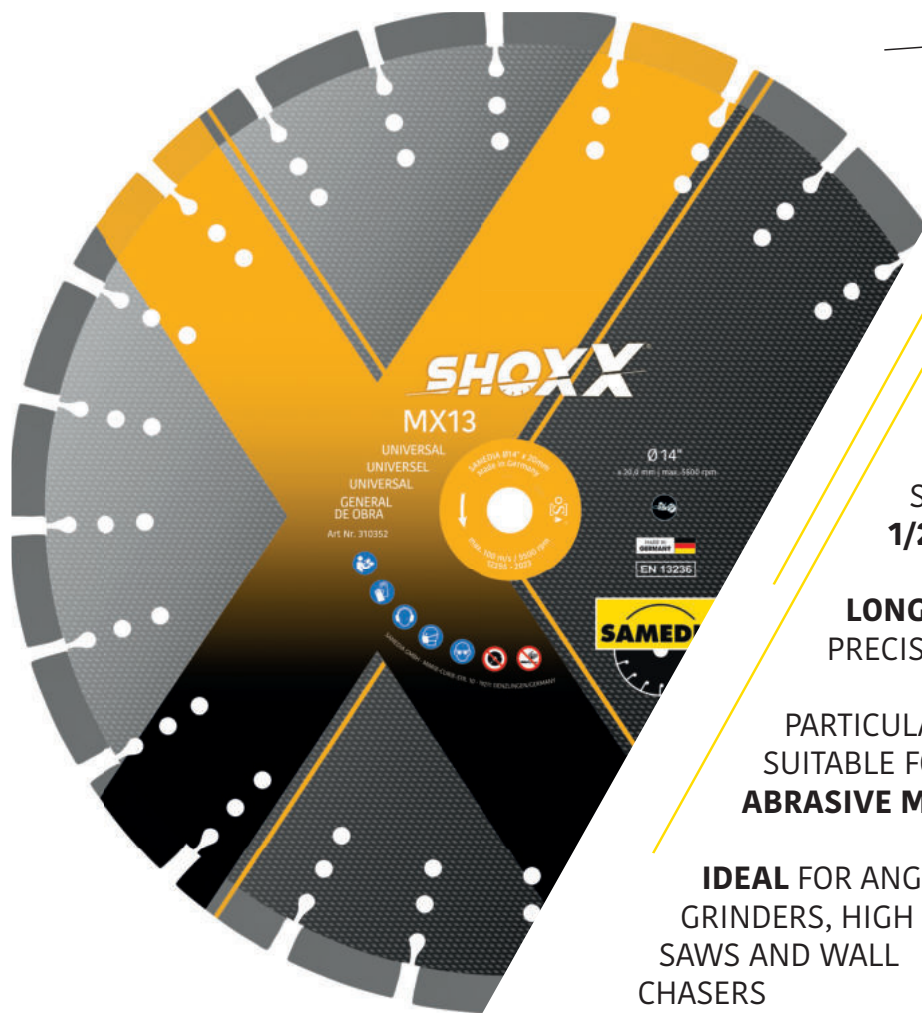

**HIGH-END
DIAMOND BLADE**

WITH **SHOXX**
FORGED SEGMENTS

SEGMENT HEIGHT:
1/2"

**LONG-LIFE PRODUCTS
PRECISE CUT**









PARTICULARLY
SUITABLE FOR
ABRASIVE MATERIALS

**IDEAL FOR ANGLE
GRINDERS, HIGH SPEED
SAWS AND WALL
CHASERS**

SHOXX® MX13

ITEM No.	SIZE - INCHES	NUMBER OF SEGMENTS
510 345	4,5 x .094 x 7/8	8
510 346	5 x .102 x 7/8	9
510 617	5,5 x .102 x 7/8	10
510 347	6 x .102 x 7/8	11
510 348	7 x .094 x 7/8	13
510 349	9 x .102 x 7/8	16
600 000	10 x .110 x 7/8 - 5/8	17
510 350	12 x .110 x 20 mm	20
510 351	12 x .110 x 1 PH*	20
510 352	14 x .118 x 20 mm	24
510 353	14 x .118 x 1 PH*	24
510 354	16 x .126 x 20 mm	28
510 355	16 x .126 x 1 PH*	28

MATERIALS

- Reinforced concrete 
- Concrete products 
- (Highly-dense) sand-lime brick 
- Concrete abrasive 
- Brickwork 
- Brick 
- Hollow block 
- Fire clay, fire bricks 
- Sandstone 

Additional blade sizes available on request.

 * included ring: 1" to 20mm x .295.



MASTER MST



FEATURES

- Premium diamond blade
- Segment height: 7/16"
- Universal range of applications

MATERIALS

- Reinforced concrete ●
- Concrete products ●
- Concrete abrasive ●
- Sandstone brick ●
- Brickwork, bricks ●

ITEM No.	SIZE - INCHES	NUMBER OF SEGMENTS
500 009	4,5 x .094 x 7/8	7
500 055	5 x .094 x 7/8	8
510 045	6 x .094 x 7/8	11
510 368	7 x .094 x 7/8	12
510 783	8 x .102 x 7/8	12
510 678	8 x .102 x 1	12
500 010	9 x .102 x 7/8	15
510 369	12 x .110 x 20 mm	18
510 370	12 x .110 x 1	18
510 371	14 x .118 x 20 mm	21
510 372	14 x .118 x 1	21
510 373	16 x .126 x 20 mm	24
510 374	16 x .126 x 1	24

Additional blade sizes available on request.

MASTER MTT



FEATURES

- Premium diamond blade
- Segment height: 3/8"
- For angle grinders and wall chasers

MATERIALS

- Concrete products ●
- Brickwork ●
- Roof tiles ●
- Sandstone brick ●
- Concrete abrasive ●
- Natural stone ●

ITEM No.	SIZE - INCHES	NUMBER OF SEGMENTS
500 092	4,5 x .087 x 7/8	1
500 011	5 x .087 x 7/8	1
511 059	7 x .102 x 7/8	1
500 056	9 x .102 x 7/8	1

MASTER TPM

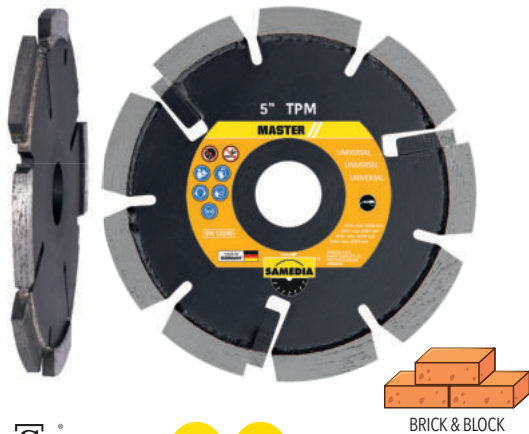

 EN 13236 compliant



MADE IN GERMANY 

LASER WELDED 

FEATURES

- Tuck Point premium diamond blade
- Segment height: 3/8"
- For joint and slot cutting, 1/4" and 5/16" cut width
- Optimum undercutting protection
- Very high lifetime value

MATERIALS

Abrasive cement joints	●
Hard cement joints	●
Mortar joints	◐

ITEM No.	SIZE - INCHES	NUMBER OF SEGMENTS
510 227	4,5 x 15/64 x 7/8	8
510 180	5 x 15/64 x 7/8	8

TECHNIC MES



 EN 13236 compliant



FEATURES

- Standard diamond blade
- Segment height: 3/8"
- Universal for construction site
- With packing unit 10 (supplied in cardboard box)

MATERIALS

Concrete products	●
Brickwork	●
Roof tiles	●
Concrete abrasive	◐

ITEM No.	SIZE - INCHES	NUMBER OF SEGMENTS
510 582	4,5 x .071 x 7/8	9
510 583	5 x .071 x 7/8	10
510 584	9 x .094 x 7/8	16

TECHNIC TPT

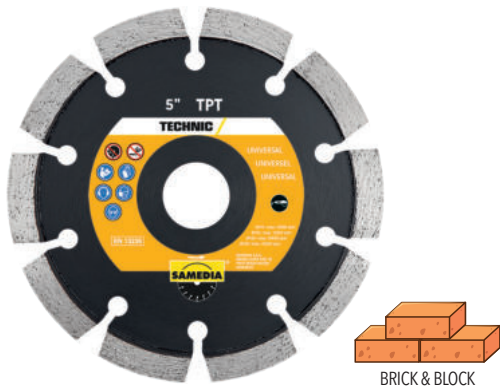

FEATURES

- Tuck Point standard diamond blade
- Segment height: 3/8"
- For joint and slot cutting, 1/4" and 3/8" cut width

MATERIALS

- Hard cement joints ●
- Sandstone ●
- Brick ●

ITEM No.	SIZE - INCHES	NUMBER OF SEGMENTS
510 252	4,5 x .252 x 7/8	9
510 253	5 x .252 x 7/8	10



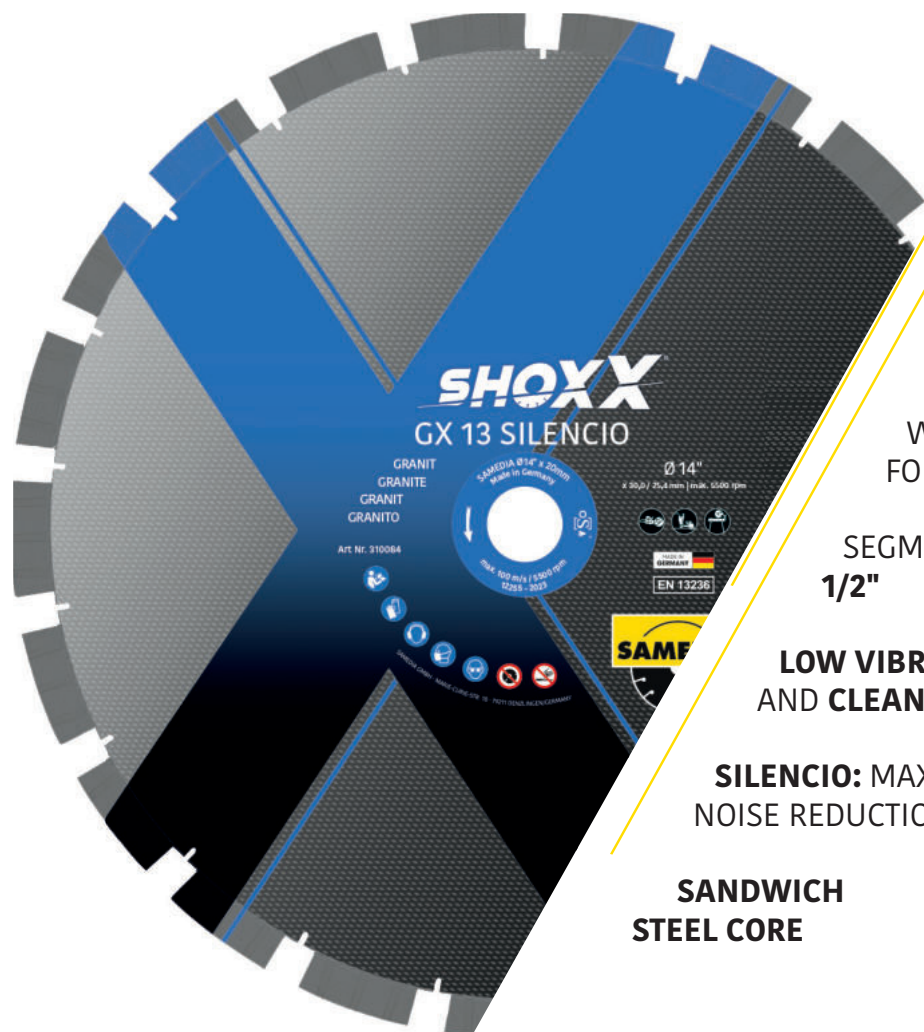

**HIGH-END
DIAMOND BLADE**

WITH **SHOXX**
FORGED SEGMENTS

SEGMENT HEIGHT:
1/2"

**LOW VIBRATION
AND CLEAN CUT**

**SILENCIO: MAXIMUM
NOISE REDUCTION**

**SANDWICH
STEEL CORE**

SHOXX[®] GX13 SILENCIO

ITEM No.	SIZE - INCHES	NUMBER OF SEGMENTS
510 083	9 x .102 x 7/8	15
511 501	14 x .118 x 1	21
510 823	16 x .126 x 30 mm	24
511 392	18 x .142 x 1	26

MATERIALS

Granite	●
Natural stone	●
Reinforced concrete	●
Washed concrete	●
Concrete products	●
Quartz	●
Porphyry	●

Additional blade sizes available on request.



SHOXX® GX13



FEATURES

- High-end diamond blade with SHOXX forged segments
- Segment height: 1/2"
- Long-life products & cut quality
- Low vibration and precise cut

MATERIALS

Granite	●
Natural stone	●
Reinforced concrete	●
Washed concrete	●
Concrete products	●
Quartz	●
Porphyry	●

Table saws only :

ITEM No.	SIZE - INCHES	NUMBER OF SEGMENTS
500 106	9 x .102 x 7/8	16
510 010	12 x .110 x 1	18
510 009	14 x .118 x 1	21
510 822	16 x .126 x 1	24

Gas saws only :

ITEM No.	SIZE - INCHES	NUMBER OF SEGMENTS
600 001	12 x .110 x 20 mm	16
500 110	14 x .118 x 20 mm	18
600 002	16 x .126 x 20 mm	24

Additional blade sizes available on request.

SHOXX® GX20 SILENCIO



FEATURES

- High-end diamond blade with SHOXX forged segments
- Segment height: 3/4"
- Ideal for bridge saws
- Max. noise reduction thanks to SILENCIO steel core

MATERIALS

Granite	●
Hard stone	●
Reinforced concrete	●
Concrete products	●
Quartz	●
Porphyry	●

ITEM No.	SIZE - INCHES	NUMBER OF SEGMENTS
510 393	16 x .126 x 60	24
510 335	20 x .150 x 60	30
510 385	24 x .189 x 60	36

Pinholes on request.
Different bore size available on request

MASTER GSM SILENCIO



 EN 13236 compliant



MADE IN GERMANY 

LASER WELDED 

FEATURES

- Premium diamond blade
- Segment height: 7/16"
- Maximum noise reduction thanks to SILENCIO sandwich steel core

MATERIALS

Granite	●
Natural stone	●
Reinforced concrete	●
Washed concrete	●
Concrete products	●
Quartz	●
Porphyry	●

ITEM No.	SIZE - INCHES	NUMBER OF SEGMENTS
511 061	5 x .102 x 7/8	9
511 043	9 x .102 x 7/8	15
511 052	10 x .102 x 1	17
511 044	12 x .102 x 1	18
511 045	14 x .118 x 1	21
511 046	16 x .126 x 1	24
511 047	18 x .142 x 1	26
511 048	20 x .157 x 1	30
511 049	24 x .181 x 1	36
511 050	28 x .181 x 1	40

Additional blade sizes available on request.

MASTER GTM



 EN 13236 compliant



FEATURES

- Premium diamond blade
- Segment height: 3/8"
- Continuous Turbo rim
- For precision cuts with angle grinders and table saws

MATERIALS

Granite	●
Natural stone	●
concrete products	●
Quartz	●
Travertine	●
Porphyry	●
(Hard) roof tiles	●
Porcelain stoneware	●
Concrete	●

ITEM No.	SIZE - INCHES	NUMBER OF SEGMENTS
510 237	4,5 x .087 x 7/8	1
510 238	5 x .087 x 7/8	1
510 590	7 x .094 x 7/8	1
510 239	9 x .102 x 7/8	1
600 008	12 x .110 x 20 mm	1
510 387	12 x .110 x 1	1
600 009	14 x .110 x 20 mm	1
510 388	14 x .110 x 1	1

Additional blade sizes available on request.
Different bore size available on request



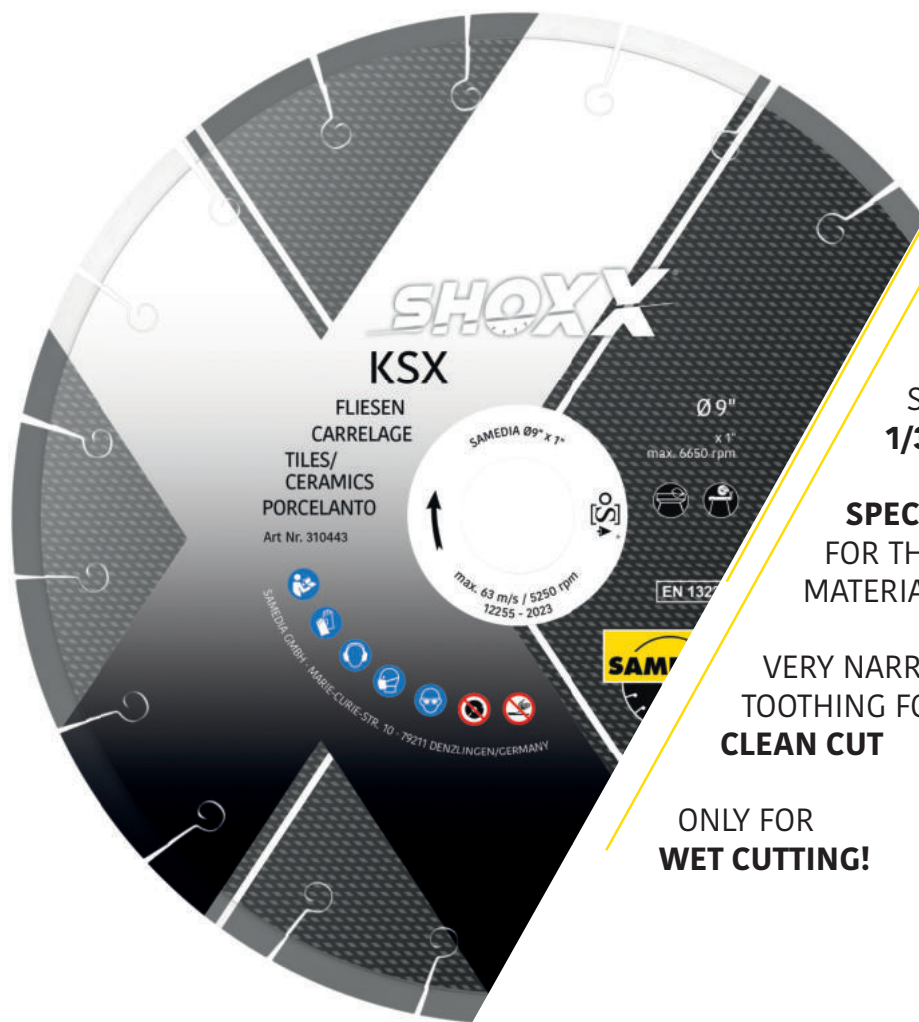

**HIGH-END
DIAMOND BLADE**

SEGMENT HEIGHT:
1/3"

**SPECIAL ALLOY
FOR THE HARDEST
MATERIALS & MARBLE**

**VERY NARROW
TOOTHING FOR A
CLEAN CUT**

**ONLY FOR
WET CUTTING!**

SHOXX® KSX

ITEM No.	SIZE - INCHES	NUMBER OF SEGMENTS
510 441	7 x .079 x 1	14
510 442	8 x .079 x 1	16
510 443	9 x .079 x 1	18
510 444	10 x .087 x 1	20
510 445	12 x .094 x 1	24
510 446	14 x .094 x 1	28
510 588	16 x .110 x 1	32
511 071	20 x .134 x 1	36

MATERIALS

- Porcelain stoneware, stoneware ●
- All types of ceramic tiles ●
- Ceramic terrace tiles ●
- Granite tiles ●
- Glazed stove tiles ●
- Marble ●



Additional blade sizes available on request.

SHOXX® K VX



EN 13236 compliant



FEATURES

- High-end diamond blade
- Segment height: 1/3"
- Can be used in dry and wet cutting
- Extremely clean cutting edges
- For angle grinders and table saws

MATERIALS

- Porcelain stoneware
- Stoneware
- All types of ceramic tiles
- Granite tiles
- Glazed stove tiles
- Glazed ceramics

ITEM No.	SIZE - INCHES	NUMBER OF SEGMENTS
511 025	4,5 x .059 x 7/8	1
511 026	5 x .059 x 7/8	1
511 078	6 x .063 x 7/8	1
511 079	7 x .063 x 1	1
511 080	8 x .063 x 1	1
511 092	9 x .063 x 1	1
511 082	10 x .063 x 1	1
511 083	12 x .079 x 1	1
511 084	14 x .079 x 1	1

Additional blade sizes available on request.

MASTER KTM



EN 13236 compliant



FEATURES

- Premium diamond blade
- Segment height: 3/8"
- With reinforced flange
- Straight cut and smooth running
- Quick & clean cut

MATERIALS

- Porcelain stoneware
- Stoneware
- All types of ceramic tiles
- Granite tiles
- Marble
- Glazed ceramics

ITEM No.	SIZE - INCHES	NUMBER OF SEGMENTS
530 016	4,5 x .055 x 7/8	1
530 017	5 x .055 x 7/8	1
530 024	9 x .063 x 7/8	1

MASTER KCM



FEATURES

- Premium diamond blade
- Segment height: 9/32"
- Continuous rim for clean cut
- Dry and wet cutting

MATERIALS

- Porcelain stoneware ●
- Stoneware ●
- All types of ceramic tiles ●
- Glazed stove tiles ●
- Glazed ceramics ●
- Granite tiles ●

ITEM No.	SIZE - INCHES	NUMBER OF SEGMENTS
500 001	4,5 x .059 x 7/8	1
500 002	5 x .059 x 7/8	1
510 015	6 x .059 x 1	1
500 003	7 x .063 x 1	1
500 004	8 x .063 x 1	1
500 005	9 x .063 x 7/8	1
510 283	9 x .063 x 1	1
500 006	10 x .063 x 1	1
500 007	12 x .079 x 1	1
500 053	14 x .079 x 1	1

Additional blade sizes available on request.

MASTER KJM



FEATURES

- Premium diamond blade
- Segment height: 9/32"
- With reinforced flange (up to Ø 9")
- Extra thin Turbo rim
- Quick & clean cut

MATERIALS

- Porcelain stoneware ●
- Stoneware ●
- All types of ceramic tiles ●
- Granite tiles ●
- Ceramic terrace tiles ●
- Glazed ceramics ●

ITEM No.	SIZE - INCHES	NUMBER OF SEGMENTS
510 626	4,5 x .055 x 7/8	1
510 627	5 x .055 x 7/8	1
510 628	6 x .055 x 1	1
510 629	7 x .063 x 1	1
530 023	8 x .063 x 1	1
510 630	9 x .063 x 7/8	1
510 631	10 x .063 x 1	1
510 632	12 x .087 x 1	1
510 358	14 x .087 x 1	1

Additional blade sizes available on request.

TECHNIC KCT



FEATURES

- Standard diamond blade
- Segment height: 9/32"
- Clean cut
- Not suitable for porcelain stoneware

MATERIALS

- All types of ceramic tiles ●
- Stoneware ●

ITEM No.	SIZE - INCHES	NUMBER OF SEGMENTS
530 008	4,5 x .063 x 7/8	1
530 009	5 x .063 x 7/8	1
530 010	7 x .063 x 1	1
530 011	8 x .063 x 1	1

Additional blade sizes available on request.

EN 13236 compliant





**HIGH-END
DIAMOND BLADE**

WITH **SHOXX**
FORGED SEGMENTS

SEGMENT HEIGHT:
1/2"

LONG-LIFE PRODUCTS

**DEEP PROTECTION
SEGMENTS**

LOW VIBRATION

**IDEAL FOR HIGH SPEED
SAWS, WALK BEHIND
SAWS UP TO 13 HP**

SHOXX[®] AX13

ITEM No.	SIZE - INCHES	NUMBER OF SEGMENTS
510 336	12 x .110 x 20 mm	18
510 337	12 x .110 x 1PH*	18
510 338	14 x .118 x 20 mm	21
510 339	14 x .118 x 1PH*	21
510 340	16 x .126 x 20 mm	24
510 341	16 x .126 x 1PH*	24
510 342	18 x .142 x 1PH*	25
510 343	20 x .142 x 1PH*	30
510 344	24 x .5/32 x 1PH*	35
600 055	26 x .157 x 1PH*	36

Additional blade sizes available on request.

 * included ring: 1" to 20mm x .295.

MATERIALS

- Asphalt 
- Abrasive concrete 
- Screed 

 EN 13236
compliant



MADE IN  GERMANY

LASER
WELDED 

MASTER ASM



FEATURES

- Premium diamond blade
- Segment height: 7/16"
- DEEP protection segments
- Ideal for high speed saws, walk behind saws up to 13 HP

MATERIALS

Asphalt	
Abrasive concrete	
Screed	

ITEM No.	SIZE - INCHES	NUMBER OF SEGMENTS
510 131	12 x .110 x 20 mm	18
500 044	12 x .110 x 1PH*	18
510 132	14 x .118 x 20 mm	21
500 045	14 x .118 x 1PH*	21
510 134	16 x .126 x 20 mm	24
500 046	16 x .126 x 1PH*	24
500 087	18 x .142 x 1PH*	25
510 129	20 x .142 x 1PH*	30
510 130	24 x .5/32 x 1PH*	35
510 029	28 x .181 x 1PH*	40
510 031	32 x .181 x 1PH*	45

Additional blade sizes available on request.

* included ring: 1" to 20mm x .295.

TECHNIC AST



FEATURES

- Standard diamond blade
- Segment height: 7/16"
- DEEP protection segments
- Ideal for high speed saws and walk behind saws up to 10 HP

MATERIALS

Asphalt	
Abrasive concrete	
Screed	

ITEM No.	SIZE - INCHES	NUMBER OF SEGMENTS
510 075	12 x .118 x 20 mm	18
500 047	12 x .118 x 1PH*	18
500 052	14 x .118 x 20 mm	21
510 076	14 x .118 x 1PH*	21
510 072	16 x .126 x 1PH*	24
510 077	18 x .142 x 1PH*	25
510 118	20 x .142 x 1PH*	30

Additional blade sizes available on request.

* included ring: 1" to 20mm x .295.

SHOXX®

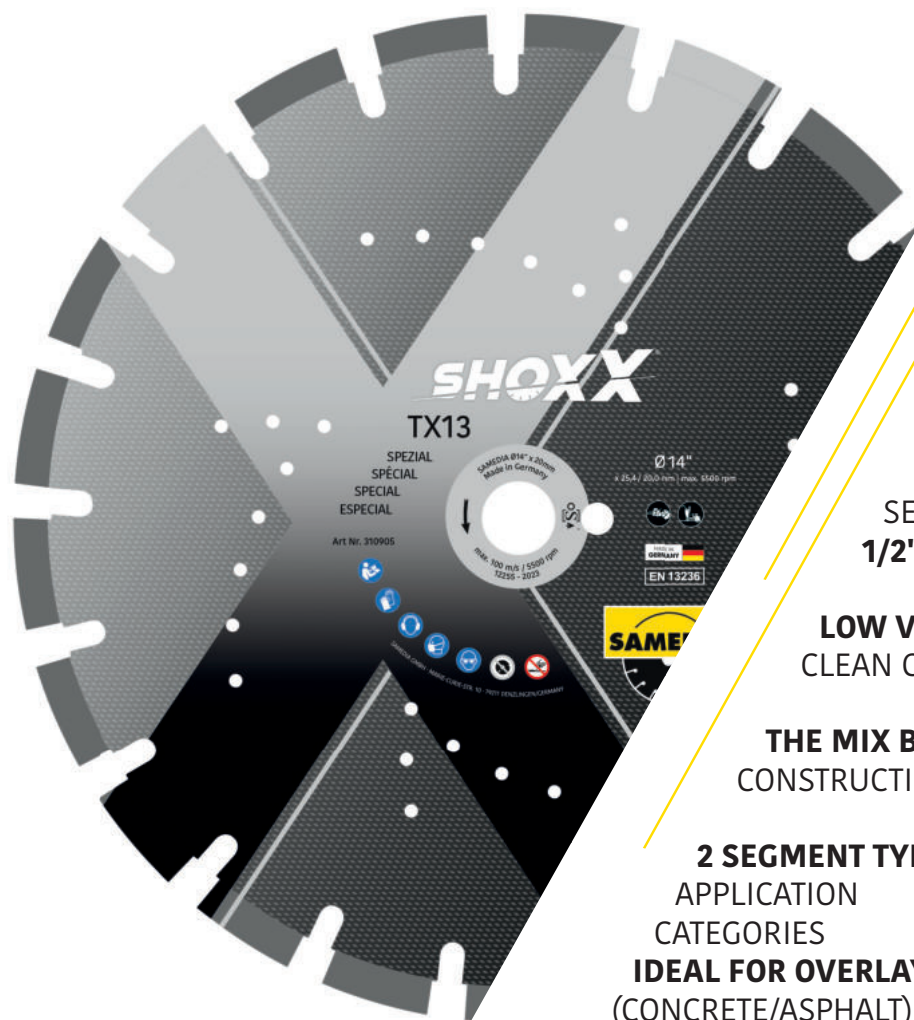

**HIGH-END COMBO
DIAMOND BLADE**

WITH **SHOXX**
FORGED SEGMENTS

SEGMENT HEIGHT:
1/2"

**LOW VIBRATION AND
CLEAN CUT**

**THE MIX BLADE FOR
CONSTRUCTION**

**2 SEGMENT TYPES -
APPLICATION
CATEGORIES
IDEAL FOR OVERLAY
(CONCRETE/ASPHALT)**







SHOXX® TX13

ITEM No.	SIZE - INCHES	NUMBER OF SEGMENTS
510 910	9 x .110 x 7/8	15
510 911	12 x .110 x 20 mm	18
510 912	12 x .110 x 1PH*	18
510 913	14 x .118 x 20 mm	24
510 905	14 x .118 x 1PH*	24
510 914	16 x .126 x 20 mm	24
510 915	16 x .126 x 1PH*	24
510 916	18 x .142 x 1PH*	25

Additional blade sizes available on request.

 * included ring: 1" to 20mm x .295.

MATERIALS

Reinforced concrete	
Concrete	
Asphalt	
Brickwork	
Screed	
Cast iron	



EN 13236
compliant



MASTER COMBO



FEATURES

- Premium Mix blade for asphalt and concrete (alternative use)
- Segment height: 1/2"
- Fast cutting (alternated castelated segments) and long life!
- Ideal for gas saws
- Professional road makers, landscapers, pipe network works...

MATERIALS

Reinforced concrete	●
Concrete	●
Asphalt	●
Brickwork	●
Screed	◐
Cast iron	◐
Granite	◐

ITEM No.	SIZE - INCHES	NUMBER OF SEGMENTS
513 439	12 x .110 x 20 mm	20
513 845	12 x .110 x 1PH*	20
513 679	14 x .118 x 20 mm	22
513 693	14 x .118 x 1PH*	22
513 610	16 x .126 x 20 mm	24
513 611	16 x .126 x 1PH*	24

Additional blade sizes available on request.

 *included ring: 1" to 20mm x .295.

MASTER FSM



FEATURES

- Premium green concrete blade
- Segment height: 7/16"
- With brazed TIP-Segments for steel core protection
- For floor saws up to 33 HP

MATERIALS

Green concrete up to 24 h. ●

ITEM No.	SIZE - INCHES	NUMBER OF SEGMENTS
511 486	12 x .110 x 1PH*	20
510 030	14 x .126 x 1PH*	24
510 273	16 x .126 x 1PH*	28

Additional blade sizes available on request.

 * included ring: 1" to 20mm x .295.



MASTER FSA



FEATURES

- Premium green concrete blade
- Segment height: 3/8"
- With brazed TIP-Segments for steel core protection
- For floor saws up to 13 HP

MATERIALS

Wet concrete 24 to 48 h. ●
Pre-stressed concrete ●

ITEM No.	SIZE - INCHES	NUMBER OF SEGMENTS
510 930	12 x .110 x 1PH*	20
510 403	14 x .110 x 1PH*	24
510 301	16 x .126 x 1PH*	28

Additional blade sizes available on request.

 * included ring: 1" to 20mm x .295.



SHOXX® KX13



EN 13236 compliant



MADE IN GERMANY

LASER WELDED

FEATURES

- High-end diamond blade with SHOXX forged segments
- Segment height: 1/2"
- For hard bricks, pavors
- Particularly suitable for 3 HP table saws

MATERIALS

Hard bricks	●
Concrete products	●
Limestone	●
Slate	●
Travertine	●
Concrete	◐

ITEM No.	SIZE - INCHES	NUMBER OF SEGMENTS
510 142	9 x .102 x 7/8	15
510 088	12 x .110 x 1	18
600 012	14 x .118 x 1	21
510 535	16 x .118 x 1	24

Additional blade sizes available on request.

SHOXX® KX13 SILENCIO



EN 13236 compliant



MADE IN GERMANY

LASER WELDED

FEATURES

- High-end diamond blade with SHOXX forged segments
- Segment height: 1/2"
- Maximum noise reduction thanks to SILENCIO sandwich core
- For hard bricks, pavors
- Particularly suitable for 3 HP table saws

MATERIALS

Hard bricks	●
Concrete products	●
Limestone	●
Slate	●
Travertine	●
Concrete	◐

ITEM No.	SIZE - INCHES	NUMBER OF SEGMENTS
510 143	9 x .102 x 7/8	15
510 092	12 x .110 x 1	20
510 093	14 x .118 x 1	24

Additional blade sizes available on request.

SHOXX® CLEAN CUT

Product non on stock. Only available upon request, please contact SAMEDIA.



FEATURES

- Electro-plated diamond on both sides
- Precise and clean job

MATERIALS

Ceramic tiles	●
Marble, hard limestone	●
Plastic PVC	●
Cast iron	●
Natural Stone	●
Concrete	◐

ITEM No.	SIZE - INCHES	NUMBER OF SEGMENTS
600 020	4 x .100 x 5/8 straight	1
600 021	4 x .100 x 5/8-11	1
600 022	4,5 x .100 x 5/8 straight	1
600 023	4,5 x .100 x 5/8-11	1
600 024	5 x .100 x 5/8 straight	1
600 025	5 x .100 x 5/8-11	1

Additional blade sizes available on request.

MASTER V-CRACK CHASER VFM



FEATURES

- Premium V-chaser milling cutter
- Segment height: 15/32"
- For repairing cracks
- Segment width 3/8"
- Only for wet cutting

MATERIALS

Asphalt	●
Screed	●
Concrete	●

ITEM No.	SIZE - INCHES	NUMBER OF SEGMENTS
510 413	5 x .15/32 x 7/8	9

Additional blade sizes available on request.

MASTER RFM

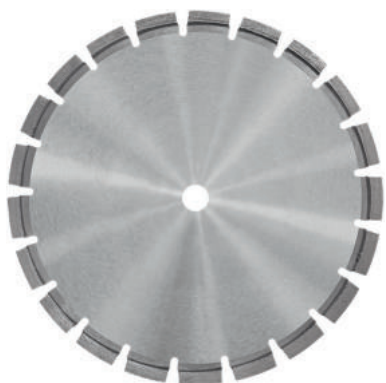

FEATURES

- Premium milling wheel for crack/joint widening
- Segment height: 3/8"
- Special alloy for asphalt and concrete
- For floor saws up to 33 HP

MATERIALS

Asphalt	●
Screed	●
Concrete	●

ITEM No.	SIZE - INCHES	NUMBER OF SEGMENTS
510 633	14 x .5/16 x 1PH*	21
510 521	14 x .25/25 x 1PH*	21

Additional blade sizes available on request.

 * included ring: 1" to 20mm x .295.

MASTER PVM



EN 13236 compliant



FEATURES

- Premium diamond tool
- Diamond height: 1/8"
- Combined tool for cutting and bevelling pipes
- Vacuum brazed diamond coating
- 20° chamfer

MATERIALS

- PVC pipes ●
- Sewer pipes ●
- Ductile cast iron pipes ●
- SML pipes/gray cast iron ●

ITEM No.	SIZE - INCHES	NUMBER OF SEGMENTS
510 685	5 x .118 x 7/8	9
513 812	12 x .118 x 20 mm	22
513 831	14 x .118 x 20 mm	24

MASTER RESCUE BLADE



EN 13236 compliant



FEATURES

- Vacuum brazed All-Cut diamond blade
- Segment height: 1/8"
- Universal use/rescue blade

MATERIALS

- metals ●
- cast iron, SML pipes ●
- fibre-reinforced plastic (GPR) ●
- wood ●
- concrete products ●

ITEM No.	SIZE - INCHES	NUMBER OF SEGMENTS
510 795	4,5 x 7/8	9
510 796	5 x 7/8	10
510 797	9 x 7/8	16
510 798	12 x 1	21
600 030	12 x 20 mm	21
510 799	14 x 1	24
600 031	14 x 20 mm	24
510 800	16 x 1	28
600 032	16 x 20 mm	28

MASTER UTM IRON



EN 13236
compliant



FEATURES

- Metal cutting
- Unmatched performance up to 30 times longer life*
- Performance until 1000 cuts*
- Keeps its original diameter throughout its lifetime
- less sparks
- complete range

*compared to a traditional abrasive blade

ITEM No.	SIZE - INCHES	NUMBER OF SEGMENTS
511 794	5 x 7/8	1
511 796	9 x 7/8	1
511 797	12 x 20 mm	1
511 798	14 x 20 mm	1
511 807	16 x 20 mm	1

Size 4,5" available upon request.

MATERIALS

Iron	●
Steel	●

MASTER WOOD



FEATURES

- Carbide grit coated Premium blade
- Segment height: 1/24"
- For a clean and quick cut
- Extra-thin, little dust, durable
- Ideal for battery angle grinders

MATERIALS

Timber	●
Laminate	●
Plastics	●
GRP	●

ITEM No.	SIZE - INCHES	NUMBER OF SEGMENTS
520 027	4,5 x 7/8	8
520 023	5 x 7/8	9

TECHNIC GAV

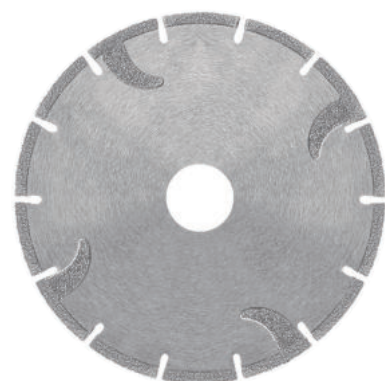

FEATURES

- Professional electro-plated diamond blade
- Segment height: 1/8"
- Clean cutting edge
- Ideal for dry-cutting of marble

MATERIALS

Marble	●
Fibre glass	●
Plastics	●
Glazed stove tiles	●

ITEM No.	SIZE - INCHES	NUMBER OF SEGMENTS
600 016	4 x 7/8	8
511 020	4,5 x 7/8	9
511 021	5 x 7/8	16
511 022	7 x 7/8	18

MASTER TKE



EN 12413 compliant

FEATURES

- Premium Corundum INOX blade
- Cuts clean & slim, without burrs and overheating
- Sulphur-free, no rust formation on stainless steel

MATERIALS

- Stainless steel ●
- Metals ●
- Non ferrous metals ●

ITEM No.	SIZE - INCHES	PACKING UNIT (PIECES)
580 869	4,5 x .039 x 7/8	1 (10 pieces/tin)
520 008	4,5 x .039 x 7/8	25
580 870	5 x .039 x 7/8	1 (10 pieces/tin)
520 009	5 x .039 x 7/8	25
520 010	9 x .039 x 7/8	25

* with packing unit 25 (supplied in a cardboard box)

MASTER TKM



EN 12413 compliant

FEATURES

- Premium Corundum METAL cutting blade
- Stable cut in thick materials

MATERIALS

- Metals ●
- Non ferrous metals ●

ITEM No.	SIZE - INCHES	PACKING UNIT (PIECES)
520 003	4,5 x .098 x 7/8	25
520 004	5 x .098 x 7/8	25
520 005	9 x .118 x 7/8	25

*with packing unit 25 (supplied in a cardboard box)

MASTER SMT



EN 13743 compliant

FEATURES

- Premium abrasive flap disc
- Highly versatile abrasive flap disc for metal processing
- Long service life with steep edges in corners

MATERIALS

- Metals ●
- NE-metals ●

ITEM No.	SIZE - INCHES	KORN	PACKING UNIT (PIECES)
520 011	4,5 x 7/8	40	10
520 012	4,5 x 7/8	60	10
520 013	4,5 x 7/8	80	10
520 014	5 x 7/8	40	10
520 015	5 x 7/8	60	10
520 016	5 x 7/8	80	10

* with packing unit 10 (supplied in a cardboard box)

SHOXX® ZU5



FEATURES

- High-End-diamond grinding cup wheel with SHOXX forged segments
- segment height: .216
- Induction welded segments under precise positioning
- minimum imbalance
- low vibration, highest removal rate
- ideal for grinders

MATERIAL

Concrete	●
Concrete products	●
Granite	●
Natural stone	●

ITEM No.	SIZE - INCHES	NUMBER OF SEGMENTS	HEIGHT OF SEGMENT (INCHES)
600 017	4x 5/8 - 11	8	.216
550 019	4,5 x 5/8 - 11	8	.216
550 002	5 x 5/8 - 11	10	.216
600 053	5 x 7/8	10	.216
600 060	6 x 19mm	10	.216
550 003	7 x 5/8 - 11	12	.216

MASTER STU



FEATURES

- Premium grinding cup wheel
- segment height: .216
- induction welded segments under precise positioning, minimum imbalance; low vibration
- especially easy to grind
- optimum dust extraction behaviour

MATERIAL

Concrete	●
Concrete products	●
Screed	●
Plaster	●
Tile adhesive	●

ITEM No.	SIZE - INCHES	NUMBER OF SEGMENTS	HEIGHT OF SEGMENT (INCHES)
550 074	4,5 x 5/8 - 11	6	.216
550 075	5 x 5/8 - 11	7	.216
600 059	6 x 19mm	9	.216
550 077	7 x 5/8 - 11	10	.216

MASTER RAPTOR



FEATURES

- The original patented first arrow segment (ice breaker coating)
- Erase resins, glues and Epoxy coatings in one pass thanks to its innovative segments
- Reinforced and specific front edges of segments
- Extremely performant
- Particularly recommended for soil and wall renovation works

MATERIAL

Epoxy	●
Glues	●
Adhesive residues	●
Paintings	●
Concrete	●
Concrete products	●

ITEM No.	SIZE - INCHES	NUMBER OF SEGMENTS	HEIGHT OF SEGMENT (INCHES)
600 004	5 x 5/8 - 11	8	.196
550 027	5 x 7/8	8	.196
600 081	6 x 19mm	10	.196
600 005	7 x 5/8 - 11	12	.196

MASTER DBK



MADE IN EUROPE



FEATURES

- Premium wet core drill for fast cutting
- Segment height .393
- Hub Thread 1-1/4" - 7
- Optimum drilling performance thanks to **Turbo Roof Top segment**
- Ideal for operations with drill rig
- Laser welded up to 10"

MATERIALS

Concrete	●
Reinforced concrete	●
Sand-lime brick	●
Brickwork	◐
Granite	◐
Concrete with flint	◐

ITEM No.	DIAMETER	RECOMMENDATION OF REVOLUTIONS (1/min; RPM)		SEGMENT HEIGHT	DRILL DEPTH
		HARD CONCRETE up to 4 m/s	ABRASIVE BRICKWORK max 7 m/s		
540009	2"	1470	2570	.393	14'
540033	2-1/4"	1336	2340	.393	14'
540005	2-1/2"	1230	2160	.393	14'
540034	2-3/4"	1093	1913	.393	14'
540251	3"	1060	1860	.393	14'
540035	3-1/4"	925	1619	.393	14'
540010	3-1/2"	830	1450	.393	14'
540002	4"	750	1310	.393	14'
540121	4-1/4"	710	1250	.393	14'
540037	4-1/2"	680	1190	.393	14'
540323	5"	630	1100	.393	14'
540012	5-1/2"	550	970	.393	14'
540013	6"	500	880	.393	14'
540014	6-1/4"	500	880	.393	14'
540248	6-1/2"	470	830	.393	14'
540016	7"	420	730	.393	14'
600056	7-1/8"	420	730	.393	14'
540018	8"	380	660	.393	14'
540019	9"	340	590	.393	14'
540020	10"	310	530	.393	14'
540036	12"	250	438	.393	14'
600057	14"	218	382	.393	14'

MASTER DBR



MADE IN EUROPE

FEATURES

- Premium Diamond Crown core bits
- V shape crown to ease the drilling process
- Segment height : .393
- Ideal for precise anchoring
- 5/8-11 Hub
- Usefull drilling length 14"

MATERIALS

Heavily reinforced concrete	●
Hard aggregates flint and other	●

ITEM No.	DIAMETER	RECOMMENDATION OF REVOLUTIONS (1/min; RPM)		SEGMENT HEIGHT	DRILL DEPTH
		2.5 to 3 m/s			
540021	1/2"	4600		.393	14'
540022	5/8"	3550		.393	14'
540023	3/4"	3000		.393	14'
540024	7/8"	2580		.393	14'
540025	1"	2250		.393	14'
540026	1-1/8"	2004		.393	14'
540027	1-1/4"	1971		.393	14'
540028	1-3/8"	1638		.393	14'
540029	1-1/2"	1500		.393	14'
540030	1-5/8"	1390		.393	14'
540031	1-3/4"	1300		.393	14'
540032	1-7/8"	1190		.393	14'

SAMEDIA PRODUCT RANGE

		LEGEND																										
		● Adapted cutting	◐ Occasional cutting	CONCRETE PRODUCTS	CONCRETE	REINFORCED CONCRETE	CONCRETE WITH FLINT	FIBER CEMENT	GRAVEL SLAB	SELF-LOCKING PAVEL	CONCRETE PLUG AND TUBE	BRICK	CONCRETE ROOF TILE	CERAMIC TILES	PORCELAIN STONWARE	ASPHALT	GREEN CONCRETE	MARBLE, HARD LIMESTONE	ABRASIVE STONE	GRANITE, NATURAL STONE	STEEL, METAL ONLY	CAST IRON	INDIAN PORCELAIN STONWARE	PLASTIC PVC	GLASS	WOOD		
CONCRETE	SHOXX UX17	1 2 3 4 5	6 7 8 9 10	●	●	●	●	●	●	●	●	●	●								●	●	●					
	SHOXX RX13	1 2 3 4 5	6 7 8 9 10	●	●	●	●	●	●	●	●	●	●								●	●	●					
	SHOXX BX13	1 2 3 4 5	6 7 8 9 10	●	●	●	●	●	●	●	●	●	●								◐	●						
	SHOXX WBX	1 2 3 4 5	6 7 8 9 10	●	●	●						◐																
	SHOXX UB13	1 2 3 4 5	6 7 8 9 10	●	●	●	●		●	●	●	●	●								◐							
	MASTER BGM	1 2 3 4 5	6 7 8 9 10	●	●	◐	◐		●	●	●	●	●								◐	●						
	MASTER BSE	1 2 3 4 5	6 7 8 9 10	●	●	◐						◐																
	MASTER USM	1 2 3 4 5	6 7 8 9 10	●	●	◐			●	●	●	●	●									●						
	MASTER BFM	1 2 3 4 5	6 7 8 9 10	●	●	◐						●										◐						
	TECHNIC USM	1 2 3 4 5	6 7 8 9 10	●	●	●																						
UNIVERSAL	SHOXX MX13	1 2 3 4 5	6 7 8 9 10	●	●	●						●	●						●									
	MASTER MST	1 2 3 4 5	6 7 8 9 10	●	●	◐	◐					●	●							●	◐							
	MASTER MTT	1 2 3 4 5	6 7 8 9 10	●								●	●							◐	◐							
	MASTER TPM	1 2 3 4 5	6 7 8 9 10	●		◐	●																					
	TECHNIC MES	1 2 3 4 5	6 7 8 9 10	●			●						●							◐								
	TECHNIC TPT	1 2 3 4 5	6 7 8 9 10	●	●		●	●					●															
GRANITE	SHOXX GX13 SILENCIO	1 2 3 4 5	6 7 8 9 10	●	●	●	●		●	◐	●	●	●								●	●	●	◐				
	SHOXX GX13	1 2 3 4 5	6 7 8 9 10	●	●	●	●		●	◐	●	●	●								●	●	●	◐				
	SHOXX GX20 SILENCIO	1 2 3 4 5	6 7 8 9 10	●	●	●	●		●	◐	●	●	●								●	●	●	◐				
	MASTER GSM SILENCIO	1 2 3 4 5	6 7 8 9 10	●	●	●	●		●	◐	●	●	●								●							
	MASTER GTM	1 2 3 4 5	6 7 8 9 10	●	◐	◐						●	●			●					●							
TILES	SHOXX KXS	1 2 3 4 5	6 7 8 9 10					◐						●	●			◐		◐								
	SHOXX KVS	1 2 3 4 5	6 7 8 9 10											●	●			●		◐								
	MASTER KTM	1 2 3 4 5	6 7 8 9 10												●	●			◐									
	MASTER KCM	1 2 3 4 5	6 7 8 9 10												●	●			◐									
	MASTER KJM	1 2 3 4 5	6 7 8 9 10												●	●			◐									
	TECHNIC KCT	1 2 3 4 5	6 7 8 9 10												●	◐			◐									
ASPHALT	SHOXX AX13	1 2 3 4 5	6 7 8 9 10		●												●	◐		◐								
	MASTER ASM	1 2 3 4 5	6 7 8 9 10		◐												●	◐		◐								
	TECHNIC AST	1 2 3 4 5	6 7 8 9 10		◐												●			◐								
MULTI-PURPOSE	SHOXX TX13	1 2 3 4 5	6 7 8 9 10	●	●	●						●	●				●	◐		◐	◐							
	MASTER COMBO	1 2 3 4 5	6 7 8 9 10	●	●	●		●	●	●	●	●	●				◐	◐		◐	◐		◐					
SPECIAL	MASTER FSM	1 2 3 4 5	6 7 8 9 10															●										
	MASTER FSA	1 2 3 4 5	6 7 8 9 10															●										
	SHOXX KX13	1 2 3 4 5	6 7 8 9 10	●	◐							●																
	SHOXX KX13 SILENCIO	1 2 3 4 5	6 7 8 9 10	●	◐							●																
	SHOXX CLEAN CUT	1 2 3 4 5	6 7 8 9 10	◐	◐	◐	◐	◐	◐	◐	◐	◐	◐	◐	●	◐			●	◐	◐	◐	◐	◐	◐	◐	◐	◐
	MASTER CRACK CHASER VFM	1 2 3 4 5	6 7 8 9 10		●													●										
	MASTER RFM	1 2 3 4 5	6 7 8 9 10		●													●										
	MASTER PVM	1 2 3 4 5	6 7 8 9 10																				●	●		●		
	MASTER RESCUE BLADE	1 2 3 4 5	6 7 8 9 10	◐																			●	●		●		●
	MASTER UTM IRON	1 2 3 4 5	6 7 8 9 10																				●	●		●		
	MASTER WOOD	1 2 3 4 5	6 7 8 9 10	◐	◐																					●	●	
	TECHNIC GAV	1 2 3 4 5	6 7 8 9 10														◐		●						●	●		
	MASTER TKE	1 2 3 4 5	6 7 8 9 10																									
MASTER TKM	1 2 3 4 5	6 7 8 9 10																										
MASTER SMT	1 2 3 4 5	6 7 8 9 10																										
CUP WHEEL	SHOXX ZUS	1 2 3 4 5	6 7 8 9 10		●	●															●							
	MASTER STU	1 2 3 4 5	6 7 8 9 10		●	●																						
	MASTER RAPTOR	1 2 3 4 5	6 7 8 9 10		●	●																						
CORE DRILL	MASTER DBK	1 2 3 4 5	6 7 8 9 10	●	●	◐	◐	●				◐									◐							
	MASTER DBR	1 2 3 4 5	6 7 8 9 10	●	●	◐	◐	●				◐									◐							



FASTER • STRONGER • SAFER

FASTER STRONGER SAFER

**PROFESSIONAL
DIAMOND TOOLS**

SAMEDIA Corp Headquarters
233 South Wacker Drive
Suite 4400, 44th Floor
Chicago, IL 60606 - USA
Email: sales@samedia.com

SAMEDIA Operations Center
601 N. 5th Avenue.
Kankakee, IL 60901 - USA
Phone: **(779) 701-5211**
Email: sales@samedia.com



www.samedia.com