

**POWER TROWEL BLADES  
& FLOAT PANS MANUFACTURER**

**PLATE 2000** INC.



A GREAT VARIETY OF PRODUCTS  
**MADE OF THE BEST STEEL**



FLOATS AND PANS

[view products](#)



TROWELS

[view products](#)



TROWEL ARMS / MOUNTING BAR

[view products](#)

**Trackability guarantee** - all products are identified with its own serial number



ISO 9001-2015



# BLADES SPECIFICATIONS

Bright polished



Blue polished



Bright polished



6"      0,062"  
8"      0,074"

0,072"  
0,084"

0,094"  
0,094"

\*Hardened and Tempered Spring Steel: Grade # C-1075, Rockwell C41-43

# FINISH BLADES

## TROWEL BLADES

FINISH BLADES

FINISH BLADES  
W/ROUNDED CORNERS

QUICK CHANGE FINISH  
BLADES

COMBINATION BLADES

QUICK CHANGE  
COMBINATION BLADES

EDGER TROWEL BLADES

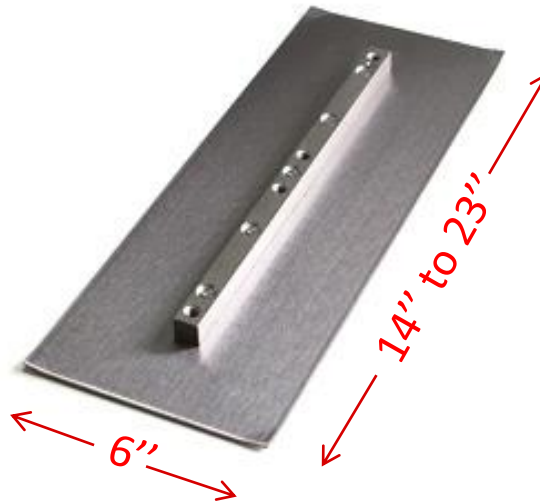

- 0,062"
- 0,072"
- 0,094"

- \*Its 6" wide make the finish blades **the most rigid** blade available
- \*Offers **gloss (shiny) finish** floors and **high FF number** (warehouse)
- \*Can be used both sides

# FINISH BLADES W/ROUDED CORNERS

## TROWEL BLADES

FINISH BLADES

FINISH BLADES  
W/ROUDED CORNERS

QUICK CHANGE FINISH  
BLADES

COMBINATION BLADES

QUICK CHANGE  
COMBINATION BLADES

EDGER TROWEL BLADES

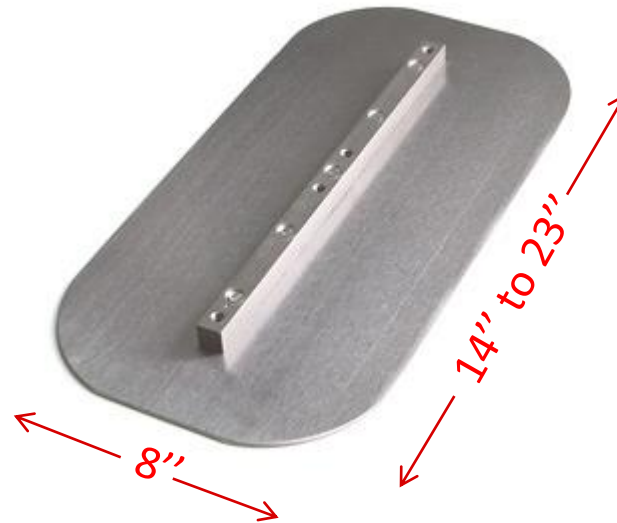

- 0,074"
- 0,084"
- 0,094"

- \*Also called **reversible combo** - can be used both sides
- \*The 8" wide **provides more flexibility** than the 6" finish blade
- \* Offers semi-gloss finish floors

# QUICK CHANGE FINISH BLADE

## TROWEL BLADES

FINISH BLADES

FINISH BLADES  
W/ROUNDED CORNERS

QUICK CHANGE FINISH  
BLADES

COMBINATION BLADES

QUICK CHANGE  
COMBINATION BLADES

EDGER TROWEL BLADES

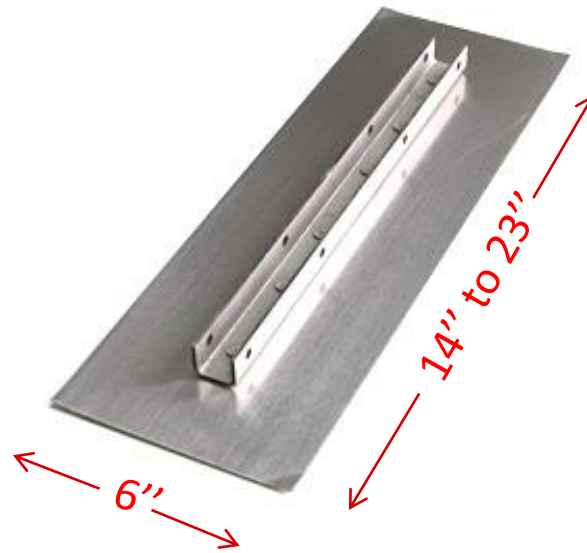

- 0,062"
- 0,072"
- 0,094"

\*50 % faster to change

\***Risk of wobble** - not as tight as the bolt-on blade

# COMBINATION BLADES

## TROWEL BLADES

FINISH BLADES

FINISH BLADES  
W/ROUNDED CORNERS

QUICK CHANGE FINISH  
BLADES

COMBINATION BLADES

QUICK CHANGE  
COMBINATION BLADES

EDGER TROWEL BLADES



- 0,074"
- 0,084"
- 0,094"

\*Its **off-center mounting** bar makes it more flexible

\* Offers **mat finish floors**

\*Mainly used where floors will be covered (carpet, ceramic)

# QUICK CHANGE COMBINATION BLADES

## TROWEL BLADES

FINISH BLADES

FINISH BLADES  
W/ROUNDED CORNERS

QUICK CHANGE FINISH  
BLADES

COMBINATION BLADES

QUICK CHANGE  
COMBINATION BLADES

EDGER TROWEL BLADES

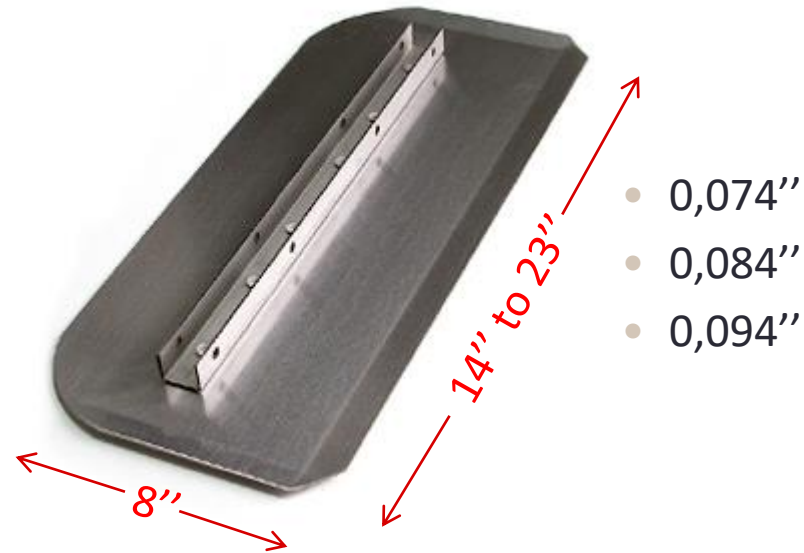

\*50 % faster to change

\***Risk of wobble** - not as tight as the bolt-on blade



# EDGER TROWEL BLADES

## TROWEL BLADES

FINISH BLADES

FINISH BLADES  
W/ROUNDED CORNERS

QUICK CHANGE FINISH  
BLADES

COMBINATION BLADES

QUICK CHANGE  
COMBINATION BLADES

EDGER TROWEL BLADES

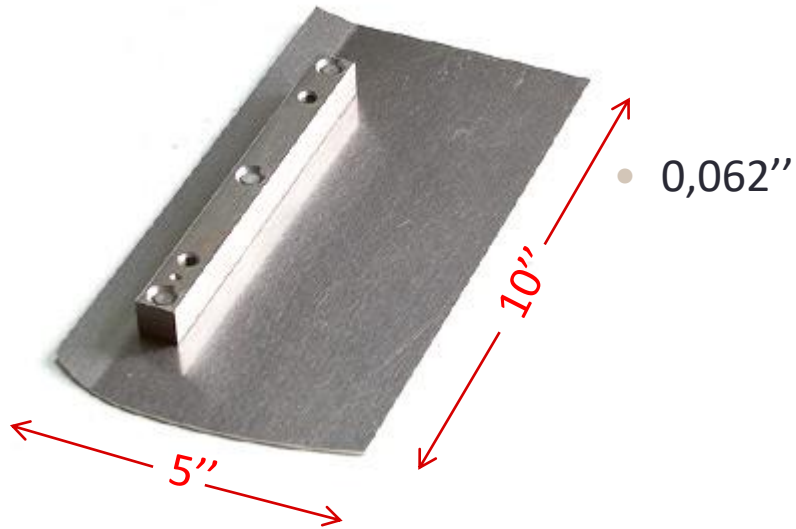

\*Finished the floor closest to the walls

# FLOAT PANS THICKNESSES

- 10 gauge steel (HRPO)
  - Longer life and more square footage

Standard 4'-5' pans

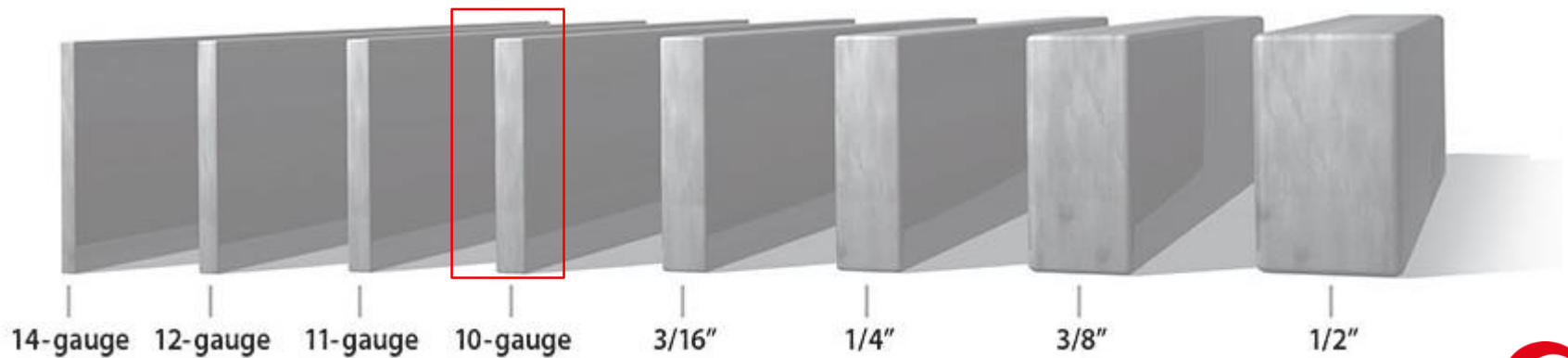

# THE ROADRUNNER - FLAT PANS

## FLOAT PANS

THE ROADRUNNER –  
FLAT PANS

THE ROCK –  
SUPER FLAT PANS

THE MASTER –  
UNIVERSAL FLAT PANS

EDGER PANS

FLOAT CLIP-ON



- The Roadrunner - 12 GA
- The Roadrunner - 11 GA
- [The Master - 10 GA](#)

 1/4" – 3/8" Rise from center

\*For easy steering & operator control

\*Mainly used on walk-behind and mechanical ride-on (lighter machine)

# THE ROCK – SUPER FLAT PANS

## FLOAT PANS

THE ROADRUNNER –  
FLAT PANS

THE ROCK –  
SUPER FLAT PANS

THE MASTER –  
UNIVERSAL FLAT PANS

EDGER PANS

FLOAT CLIP-ON



- 12 GA (Walk-behind)
- 3' - 11 GA
- 4', 5' - 10 GA



0" – 1/8" Rise from center

\*For super flat floors and high FF number

# THE MASTER - UNIVERSAL FLAT PANS

## FLOAT PANS

THE ROADRUNNER –  
FLAT PANS

THE ROCK –  
SUPER FLAT PANS

THE MASTER –  
UNIVERSAL FLAT PANS

EDGER PANS

FLOAT CLIP-ON



- 4'
- 12 GA
- 11 GA
- 10 GA

\*fit any kind of machine available in your area

\***The Master** can be made in super flat and flat pans

# EDGER PANS

## FLOAT PANS

THE ROADRUNNER –  
FLAT PANS

THE ROCK –  
SUPER FLAT PANS

THE MASTER –  
UNIVERSAL FLAT PANS

EDGER PANS

FLOAT CLIP-ON



• 14 GA



\*85° angle lip allows to finish the floor closest to the walls

# FLOAT CLIP-ON

## FLOAT PANS

THE ROADRUNNER –  
FLAT PANS

THE ROCK –  
SUPER FLAT PANS

THE MASTER –  
UNIVERSAL FLAT PANS

EDGER PANS

FLOAT CLIP-ON

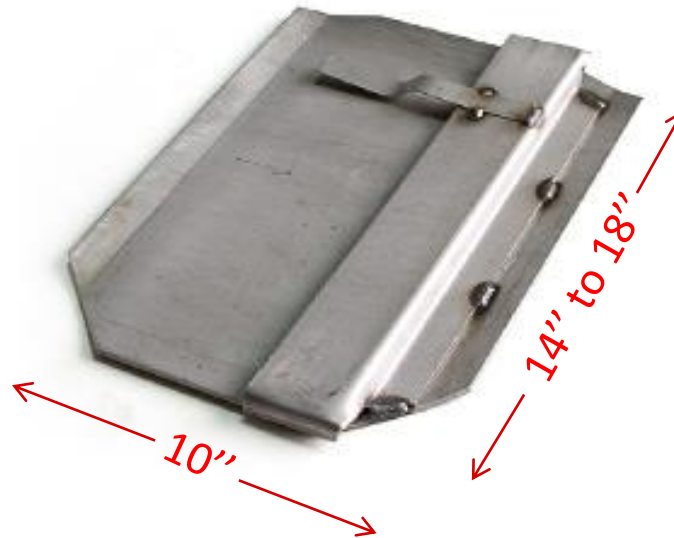

• 11 GA

\*80 % are made with 10 GA steel (waste metal from float pan cutting)

# FLOAT PANS

## PRODUCTION PROCESSUS BENEFITS

- Unique stress relief process :
  - More consistent “flat” pans
  - Eliminate waving
  - Ideal angle lips that allows mix to move under pan instead of being pushed/plowed
  - Heavy duty MIG-welded steel “Z” or safety catch bracket

**→ All those technical points improve efficiency of the pans**



# MOUNTING BARS

## FIXATIONS

MOUNTING BARS

TROWEL ARMS



14" Quick change blade  
18" Quick change blade



# TROWEL ARMS

## FIXATIONS

MOUTING BARS

TROWEL ARMS



- 36'' WB
- 48'' WB
- 6' RO
- 8' RO
- 10' RO

\*We only produce trowel arms for Bartell walk-behind and Whiteman ride-on